

CREEP FEEDERS AND WATERERS

Model 18CF Creep Feeder is perfect for starter and pre-starter pellets. Made of durable galvanized steel...easy to fill and to clean. Feed adjustment slide. Feed saver flange on trough.

Model 6160 Utility Pan one-piece galvanized steel; no seams to leak; perfect for hundreds of uses.

Model WN3 Nipple Waterer. Stainless steel body; plunger and spring. 1/2" NPT thread, 7/8" hex. Three (3) position adjustable orifice to handle most water pressures. Easily removed domed screen.



CREEP FEEDER & HOG WATERER SPECIFICATIONS

| Model No. | Description | Approx. Capacity Lbs. / Kilos | | Types of Construction | Overall Size /Inches (cm) | | | Shipping Weight Lbs. (kg) |
|-----------|----------------|--|------|-----------------------|---------------------------|------------------|-----------|---------------------------|
| | | Contents | Pigs | | W | L | H | |
| 18CF | Creep Feeder | 25 lbs. (11.4) | 24 | Galv. Steel | 8 3/4 (22.2) | 18 (45.7) | 16 (40.6) | 21.0 lbs/2 pack (9.5) |
| 6160 | Utility Pan | 2.9 Gal. / 11 ltr.) 9 lbs. / (4.1 kg) | | Galv. Steel | 16 3/4 Dia. (42.5) | X 3 3/8" H (8.6) | | 2.2 lbs (1.0) |
| WN3 | Nipple Waterer | | 25 | Stainless/Brass | 2 7/8 Long (7.3) | | | 4 oz. (.1) |

UTILITY DRINKER

Water Any Poultry, Pigs Or Other Small Animals with Brower's 20 Gallon (75.5 Liter) Utility Drinker

5.5 inch (14 cm) fill opening.

Lift off tank provides for easy cleaning. (No bolts) Also affords easy float access. Uses one model B78P valve. Adjustable.

Fourteen inches (35.6 cm) of vertical headroom easily accommodates pigs up to 40 pounds (18.2 kg).



Precise Medicating

Gallon markers (from 12 to 20 gallons in 1 gallon increments). Water level easy to read through translucent tank. Markers allow for water in the trough to be at 1 inch (2.54 cm) below flood stage.

Six 4.5 inch (11.4 cm) openings.

3/4 inch (1.9 cm) plug for complete clean out and drainage.

Mount to creep dividers or wall OR Position in the center of the pen.



UTILITY DRINKER SPECIFICATIONS

| Model No. | Capacity | Width | Length | Drink Height | Overall Height | Shipping Weight |
|-----------|--------------------------|------------------|------------------|----------------|--------------------|----------------------|
| MPD20 | 20 Gal. (75.7 liters) | 14" (35.6 cm) | 26" (66.0 cm) | 3" (7.6 cm) | 22.5" (57.2 cm) | 25 lbs. (11.4 kg) |

Minimal assembly. Shippable via ground package.



FIELD DRINKER

Precise Medicating * We're Better At The Details

Sure, you can buy plastic tanks that hold water from several sources. Brower gives you built-in easy-anchor notched flanges, more capacity (find another 85 gallon drinker), the boldest gallon markers and a handy fill line in the trough. If you talk to other manufacturers, ask them if their fill markers include the water in the trough and if so, at what depth. We give you precise medicating. Take a look at our other details...

8 inch (20.3 cm) ID threaded cap; 1.25 inch (3.18 cm) ID port with pop-out plug.

Incremental 10 gallon markers and top marker showing all 85 gallons. Water level easy to read through translucent tank.

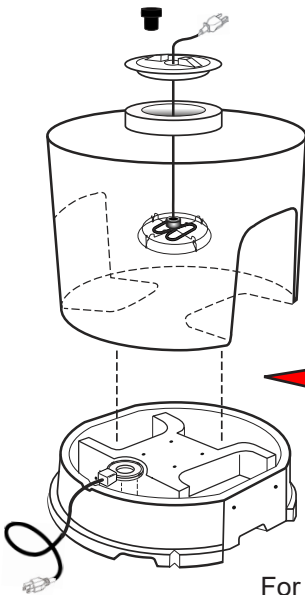

Use a 250 watt cast aluminum de-icer in the trough or equivalent. Use a thermostatically controlled heater designed for use with polyethylene in the tank. Electrical supply cord threads through port. Either option will work for you. The trough option, will do a better job with minimal drinking activity (less than say 7 head). Select the option that results in the easiest, most secure hookup for your particular operation.

For permanent installations, order optional Model 383344 stainless steel anchor package: four anchor bolts, four plates, four flat washers, four nuts (all stainless steel).

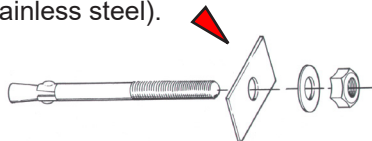

All Poly Construction. High density polyethylene. We use the best stabilizers for UV protection - both for mechanical properties and for color fastness. No rust. No corrosion. Takes more kicking abuse than any pigskin.

Two drink openings are each 15 inches (38.1 cm) high, 13.3 inches (33.8 cm) wide and 8 inches (20.3 cm) deep.

304 stainless steel bite guards.

One 2 inch (5.1 cm) drain in each drink opening. Rounded corners. Complete cleanout and drainage.

Great for pastured poultry operations and flight pens.



WARNING

All electrically heated waterers must be installed by a qualified electrician and must be properly grounded. Failure to follow these and other procedures, could result in electrocution of human beings and animals. Read and follow instructions.

SPECIFICATIONS

| Model No. | Approximate Capacity | | Base Diameter | Tank Diameter | Drink Height | Overall Height | Shipping Weight |
|---|----------------------|----------------------------|--------------------|------------------|-----------------|--------------------|----------------------|
| | Animals | Water | | | | | |
| MFD85 Field Drinker With two drinkers | 100 hogs | 85 gallons (322 liters) | 34.5" (87.6 cm) | 32" (81.3 cm) | 8" (20.3 cm) | 35.8" (90.9 cm) | 59 lbs. (26.8 kg) |

* Minimal assembly. Shipped in 2 parcels - 36 lbs. (16.4 kg) and 23 lbs. (10.4 kg). Shippable via Spee Dee (in areas serviced by Spee Dee). Otherwise, truck freight.

WATER CANTEEN

*Now There's A Better Way To Pack Water.
Our Canteen Fits Compactly In The Corner Of Your Trailer Or Tack Room.
Take It To The Fair.*

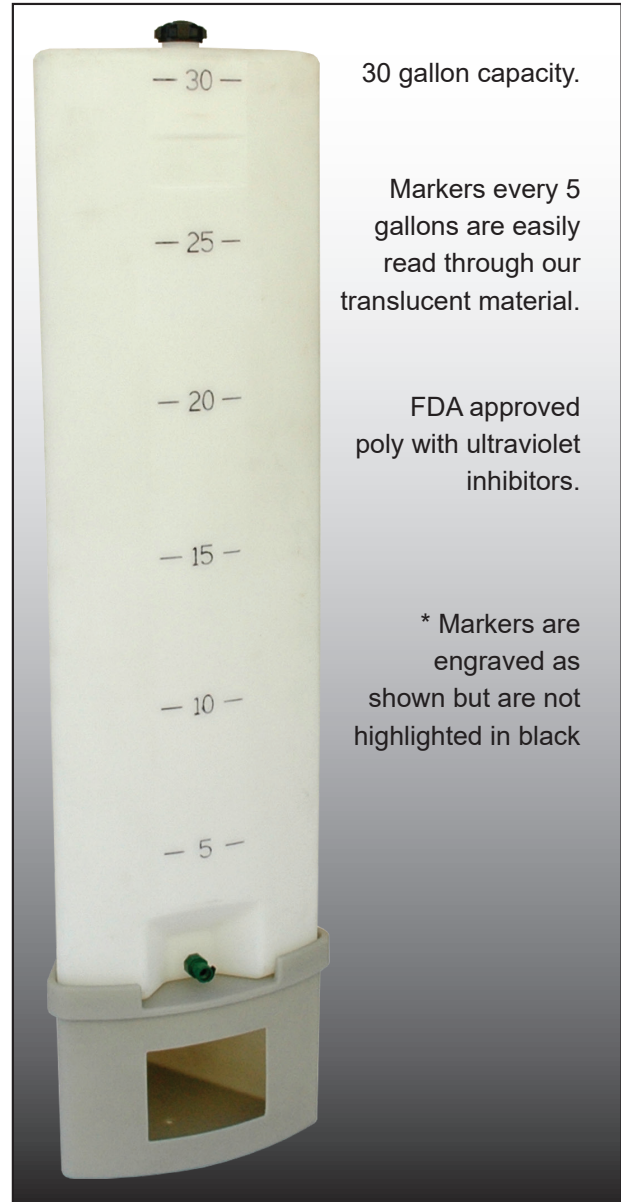

SPECIFICATIONS

| Model No. | Dimensions In Inches (cm) | | | Shipping Weight Lbs. (kg) |
|--|---------------------------|-------------------|--|---------------------------|
| | Capacity | Height | Girth | |
| MCN30 Canteen | 30 Gal. (113.6 ltr) | 54 3/4 (139.1) | 16 1/4 x 16 1/4 x 16 3/4 (41.3) x (41.3) x (42.5) | 20 (9.1) |
| MBE30 Base | | 12 1/2 (31.8) | 17 1/2 x 17 1/2 x 18 (44.4) x (44.5) x (45.7) | 6 (2.7) |
| When the Canteen is placed in the base, the height is: | | 65 3/4 (167.0) | | 26 (11.8) |

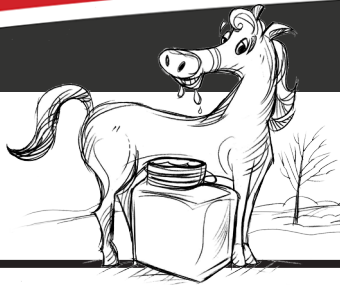

PERFORMANCE ONE INSULATED BUCKET HOLDER

A Very Simple and Effective Water Management Tool. Your Horse's Water Will Stay Warmer Under Cold Conditions and Will Stay Cooler in the Heat of Summer.



Our Performance One bucket holder includes a 5 gallon (18.9 ltr.) bucket and also includes a heat retention cover. The horse drinks from a "well" formed into the cover. Even on the coldest days, your horse should have adequate time to consume all the water you place before it. You know how much water your horse is taking. Our bucket holder will also accommodate standard 3 gallon and 5 gallon buckets.



The body is a foam-filled poly construction - solid and indestructible. Foam insulation with an R value of 7.5 per inch fills all sides and the bottom. The most effective ultraviolet inhibitor allows years of outdoor use as well.

Pre-formed mounting holes on an open flange allow for quick and sturdy installation (A). Our bucket holder stands firmly on the ground as well.

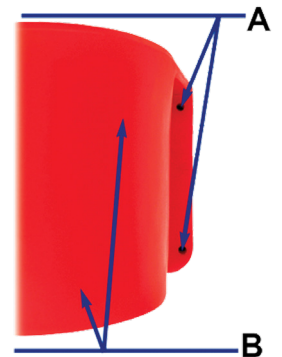

Performance One has a smooth taper to a hole in the center of the holder. This design assures total water drainage for complete and easy cleaning - no hidden standing water resulting in mosquitoes.

HOW EFFECTIVE IS OUR BUCKET HOLDER IN COLD WEATHER?

| TEMPERATURE | BUCKET HOLDER, BUCKET AND COVER | | BUCKET ONLY |
|-------------------|---------------------------------|-------------------|--------------------|
| | HOURS TO FIRST ICE | WATER TEMPERATURE | HOURS TO FIRST ICE |
| 20° F (-6.7° C) | 17.6 | 49° F (9.4° C) | 4.2 |
| 0° F (-17.8° C) | 9.2 | 45° F (7.2° C) | 3.1 |
| -10° F (-23.3° C) | 6.4 | 40° F (4.4° C) | 1.0 |

NOTES: Test conducted with 5 gallons (18.9 liters) of water.

a beginning water temperature of 59° F (15° C), no drinking activity, no wind chill.

We've Been Selling Automatic Drinkers for Decades. But We're Proud of our Bucket as Well!

When our Performance One bucket holder is filled with foam, a rigid fixture is used to evenly distribute material. Our sidewalls are smooth (B). Our overall workmanship is superb.

BUCKET HOLDER SPECIFICATIONS

| Model No. | Color | Size Inches (cm) | | | Shipping Weight Lbs. (kg) |
|---------------------------------------|-------|------------------|---------------|----------------|---------------------------|
| | | Overall Width | Overall Depth | Overall Height | |
| MBH5R Bucket Holder, Bucket and Cover | Red | 18 (45.7) | 15 (38.1) | 17 (43.2) | 15 (6.8) |
| MBH5B Bucket Holder, Bucket and Cover | Blue | 18 (45.7) | 15 (38.1) | 17 (43.2) | 15 (6.8) |

All Models shippable via ground package.

